

Cloud™ Suspended Decorative Baffle



Product Overview

Dbsorb Cloud™ range of suspended baffle installations create a modern aesthetic with excellent acoustic performance. The Cloud installations are designed to effectively reduce reverberation across a broad range of frequency.

Our Cloud baffle includes an adjustable suspension kit, requiring minimal assembly for installation that allows it to be suspended at a range of heights.

The Cloud baffle can be used to mask services above, as a cloud-like feature in open spaces, or to effectively position over large desks and work spaces.

Applications

Ceiling & Wall:
Office Interiors, Showrooms, Hospitality, Education and Residential.



No loose fibres



Composition:
100% PET (up to 60% recycled content)



Fire rating
12mm: EN 13501-1:2018: B - s1, d0



Manufactured in NZ
Non-Toxic, Non irritant
Glue Free, Low VOC



Antibacterial



Environmental:
Global Recycled Standard (GRS) 4.0
OEKO-TEX® Confidence In Textiles –
STANDARD 100. Tested for harmful
substances. Annex 6" Low VOC

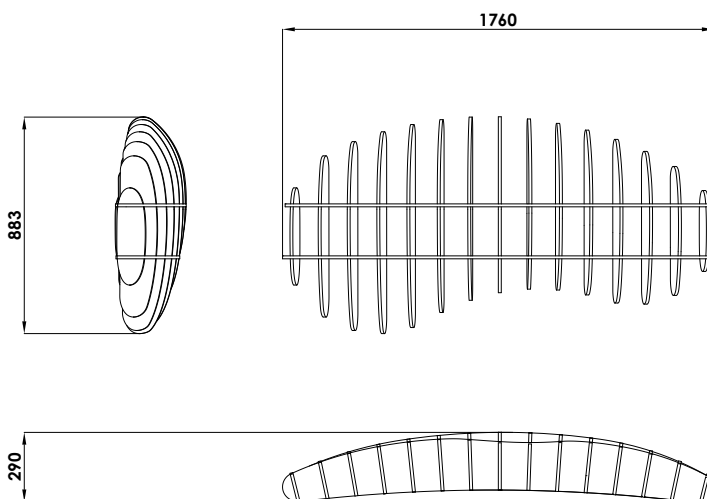

DBSORB Ltd
Acoustic Systems

www.dbsorb.co.nz

Phone: (+64) 09 553 6775

Email: sales@dbsorb.co.nz

Address: 63S Hugo Johnston Drive, Penrose
Auckland 1061

Copyright © 2022 DBSORB Ltd
All Rights Reserved

